

SCREEN MACHINE INDUSTRIES™

AN AMERICAN MANUFACTURER OF PORTABLE CRUSHING AND SCREENING EQUIPMENT

612T & 612W TROMMELS



10685 COLUMBUS PARKWAY, ETNA, OHIO 43062

1-740-927-3464

800-837-3344 (USA ONLY)

WWW.SCREENMACHINE.COM

KEY FEATURES

TROMMEL SCREEN

- **6' x 12' Trommel Drum Screen**
160 square feet (14.89 sq. m) of actual wire cloth screening surface area
- **Four Wheel Drive with Twin Motors**
Twin drive shafts generate powerful traction and prevent wheel slippage when screening heavy, wet materials
- **Heavy-Duty Trommel Drum with Massive Triangular Tumbling Paddles**
- **Unique Screen Cloth Cable/Hinge Lock Design**
Facilitates extremely quick and easy screen change or replacement
- **Self Cleaning Brushes**
Two self-cleaning adjustable tensioned nylon brushes ensure a clean screen surface for continuous operation
- **Variable RPM Drum Speed**
Drum speed can be hydraulically adjusted from 0 to 32 RPM for efficient separation of any type and size of material
- **Multiple Screen Choices and Sizes Available**
 - Square Wire Cloth
 - Slotted Wire Cloth
 - Punch Plate



POWER SYSTEM & CONTROLS

- **Yanmar® 84HP (62 kw) 4TNV98T Diesel Engine**
2200 RPM liquid cooled - ideal for dusty work sites
- **Large 70 Gallon Fuel Tank**
Over 16 hours of continuous material processing without the need to refuel
- **Wireless Remote Control Movement and Operation (612T only)**
Complete hand-held control of machine with a range of 100 yards (91.4 m)
- **Three Emergency Stops Mounted to the Machine (612T Only)**
An additional shut-off button is located on the wireless remote transmitter
- **Independent Hydraulics**
Separate valve, pump and motor for the Feeder, Screen, Conveyor and Cylinders
- **Baffled 70 Gallon Hydraulic Tank and Cooler**
A cool hydraulic system maintains a constant level of performance and long life
- **Unique Large Engine Compartment Design Allows Quick Access for Engine Maintenance**
- **Easy to Operate Control Panel with Lockable Access Doors**



STRUCTURE

- **Heavy-Duty Unibody Mainframe**

Massive unibody frame made from high quality steel handles the stresses of rough terrain movement and ensures long life integrity in the most demanding job applications

- **Modern Painting Facilities Apply Three Coats of Specially Designed Paints**

Special paints protect the steel and create a first class finish to enhance your investment



FEEDER

- **Large 4.5 Cubic Yard (3.44 cu. m) Open Ended Hopper**

Expandable to 7.5 cubic yards (5.73 cu. m) with optional hopper extension

- **Designed to Be Fed With a 1 - 3 Cubic Yard (.76 - 2.29 cu. m) Front End Loader**

Hopper can be loaded from either side

- **Low Hopper Feed Height Accommodates Most Loaders Without a Ramp**

9'-2" (2.8m) Feed Height on 612T Tracked Version

10'-4" (3.15m) Feed Height on 612W Wheeled Version

- **Hydraulically Variable Speed Feeder Belt**

Adjustment of the feeder speed controls the amount of material entering the trommel

- **36" Wide (.91m) Heavy-Duty 330 PIW Main Feeder Belt**

- **5" (127 mm) Rubber Wrap Idler**

This idler®wraps the feeder belt around the head pulley to prevent pulley slippage.

- **Precision Lagged Head and Wing Type Tail Pulleys**



CONVEYORS

- **Side Discharge Conveyor High Enough for Direct Truck Loading**

13'-11" (4.25m) discharge height on side stacking conveyor (612W)

12'-9" (3.89m) discharge height on side stacking conveyor (612T)

Variable conveyor angle ranging from 18° to 30°

- **Capable of True Wireless "On The Fly" Windrow Stockpiling (612T)**

You never have to handle screened materials twice

- **Fines Unders Belt is 42" Wide (1067 mm) 150 PIW**

- **Side Discharge Belt is 24" Wide (610 mm) 220 PIW**

- **Guide Rollers On All Conveyor Belts for Centered Belt Tracking**

- **Spring Loaded Belt Scraper Bars Made of UHMW Plastic**

- **Precision® Herringbone Lagged Head Pulleys**

- **Precision® Wing Type Tail Pulleys**

- **Goodman® 5" (127 mm) Troughing Idlers**

- **Rubber Disc Return Idlers**



SHREDDER HAMMERMILL (OPTIONAL)

- **High Speed Hammermill Shredder** (US Patent #7121487)
44 Hardened blades spinning at 1,200 RPM pulverizes dirt products creating more fines with less oversize
- **Spring Tensioned Baffle Plates Control Shredding Action**
Free swinging blades with baffles allow large rocks and other unbreakables to pass



ADDITIONAL OPTIONS

- **Oversize Material Conveyor With 36" (.91m) Wide 220 PIW Belt**
612W Stockpile Height 7'-3" (2.21m)
612T Stockpile Height 6'-1" (1.85m)
- **Tethered Pendant Movement** (612T)
A cord attached pendant can be added in addition to the standard wireless remote for added security
- **Hydraulic Tipping Grizzly with 5" (127 mm) Space Openings**
Triggered by wireless remote control
- **Hopper Extension Available for Additional Capacity**
- **Vibratory Grid**
A complete vibratory screen mounted on top of the hopper for pre-screening
Screen choices include grizzly, punch plate or woven wire cloths
Two-tiered finger deck option is available for materials with heavy vegetation



PORTABILITY

- **Heavy-Duty Tracked Undercarriage** (612T)
Wireless remote controlled movement by Cattron®
- **Large Tracked Footprint Ensures Stability On Soft Ground**
8'-3" (2.52m) ground length with 16" (400 mm) wide shoes (612T)
- **Track Movement Speed is .71 Miles (1.14 km) per Hour** (612T)
- **22,500 lb. Axle with Air Brakes** (612W)
Four 8.25-22.5 tires are standard
- **Fifth Wheel Pin Transport** (612W)
Brake lights, turn signals and mud flaps are all standard features
- **Hydraulic Landing Gear** (612W)
Allows for easy tractor connection without additional equipment
- **Hydraulic Fold-Over Conveyor for Easy Portability**



PRODUCT SUPPORT

- **Factory Headquarters Located Near Columbus, Ohio**
- **Lifetime Toll Free Engineering Telephone Support** (USA Only)
- **Responsive Warranty Support**
- **Rapid Response Parts Availability**
- **Detailed Operational, Service & Parts Manuals**
- **Extensive Distributor Network**

DIMENSIONS

612T TROMMEL

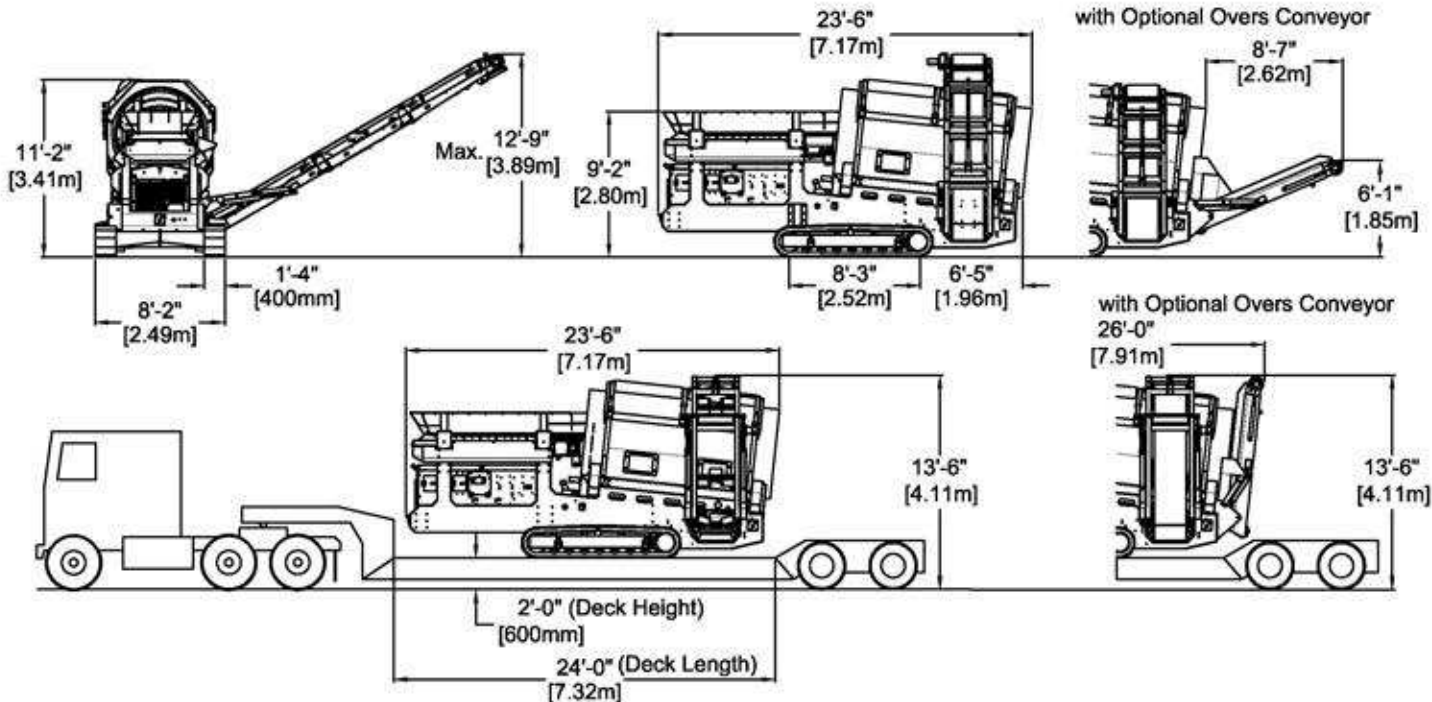

Width: 8'-6" [2.59m] Weight: (Est.) 27,000 lbs [12250kg]
 Weight with Options: (Est.) 31,800 lbs [14425kg]

612W TROMMEL

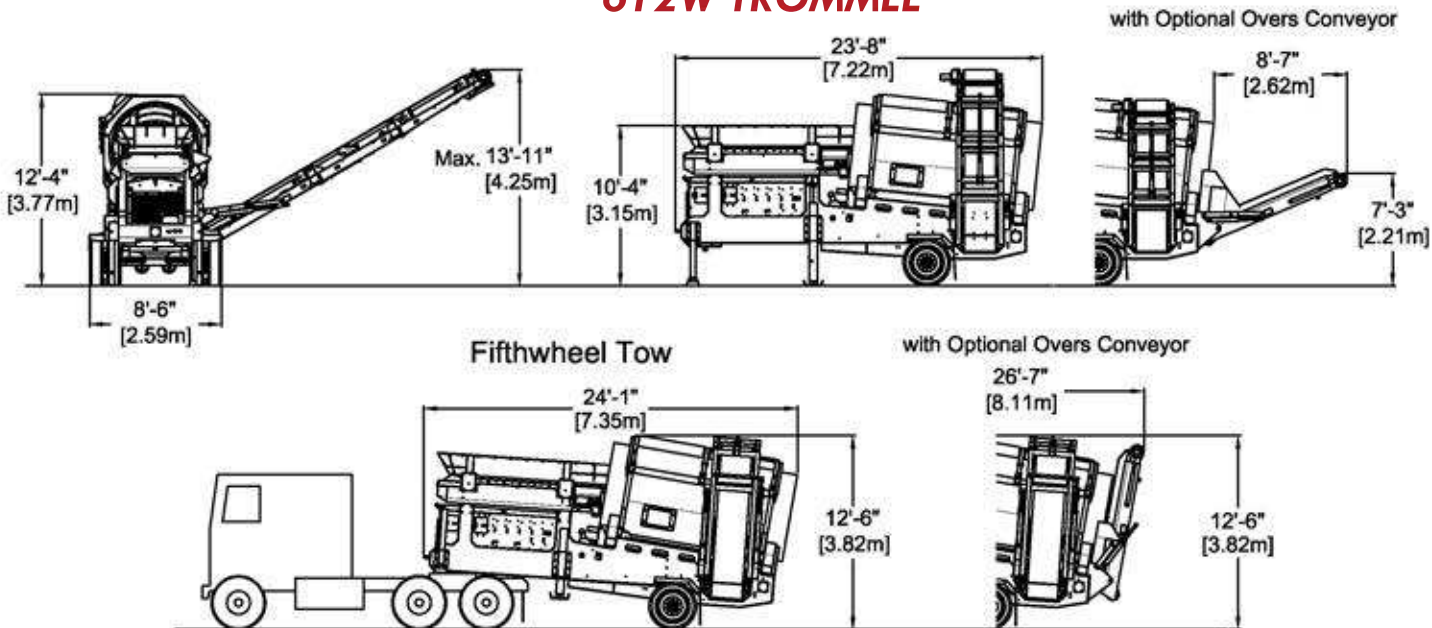

Width: 8'-6" [2.59m] Weight: (Est.) 22,500 lbs [10200kg]
 Weight with Options: (Est.) 27,300 lbs [12380kg]