

THE SCREEN MACHINE®

AN AMERICAN MANUFACTURER OF PORTABLE CRUSHING, SCREENING AND SHREDDING PLANTS & CONVEYORS

SPYDER 516T

US PATENTS
6,698,594
6,669,026



10685 COLUMBUS PARKWAY, PATASKALA, OHIO 43062

740-927-3464

800-837-3344

WWW.SCREENMACHINE.COM

Quality Engineering By Design...



1/2" Thick USA Grade 80 Steel

Precision® Pulleys

Goodman® Idlers

Dodge® Feeder Bearings

Smooth
P

Martin® Sprockets

Emergency Stops

Cummins® Tier 3
Diesel Engine

Massive Unibody Frame
USA Grade 80 Steel

Prince®
&
Parker® Valves

Fairfield® Reducers

Oilair® Coolers

Casappa® Pumps

Caterpillar® 312 Undercarriage





THE SCREEN MACHINE®

s

th Start™ Technology
Patent # 6,669,026

Goodman® Guide Rollers

Torrington® Screen Bearings

Impact Bed on Oversize Belt

Browning® Couplings

Rexnord® Couplings



Charlynn® Hydraulic Motors

Browning® Bearings

Energy® Cylinders

Gates® Hose & Fittings

riage

Manufactured By Americans
US Patent # 6,698,594

Remtron® Wireless Remote Control

.Requires Industry Leading Brands



KEY FEATURES

FEEDER

- **Feed Hopper Can Be Loaded From All Three Sides**
Patented design allows your loader to feed both hopper sides and rear
- **Hopper Walls Made of 1/2" (13mm) USA Grade 80 Steel**
Hopper strength and durability can handle the toughest applications
- **10'-0" (3m) Feed Height At Low Hopper End**
Low hopper feed height permits loading without building a ramp
- **Feed Height Lowers to 8'-3" (2.5m) When Rear Hopper Gate Is Lowered**
Direct feed from a crusher is supported - our 4043T Impact Crusher fits to perfection
- **Heavy Duty Structural Steel Impact Bed Supporting 1 1/2" (3.8cm) - Thick UHMW Plastic Liners & 5" (13cm) Impact Idlers**
Built tough to handle a wide range of raw materials
- **48" (1.22M) Wide 3 Ply 600 PIW Conveyor Belt**
- **Variable Feeder Speed Adjustment Via Wireless Remote**
The safety and control of overall productivity is piloted by wireless remote control from upwards of 300 feet away
- **Dual Motor Drive With 18" (46cm) Lagged Head Pulley**
Horsepower combined with traction equals a steady uninterrupted feed
- **Feed Length 15'-6" (4.7M) : Feed Width 7'-6" (2.3M)**
Long enough for a front end loader, wide enough for an excavator
- **11 Cubic Yard (8.4m) Hopper Capacity**
Matches with 4-6 cubic yard front end loaders & 1-3 cubic yard excavators

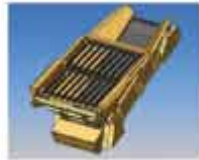

- **Optional Grizzly Available For Fourth Product Separation**
Built with USA T1 steel tapered bars
Nominal size opening 6" (150mm)
Wireless remote control hydraulic tipping

UNDERCARRIAGE

- **Caterpillar® 312 Tracked Undercarriage**
- **43 Track Shoes Each Side With 20" (500mm) Shoe Width**
- **Sealed and Lubricated Pins and Bushings**
- **Carrier Rollers (one per side)**
- **Track Gauge 7'-10" (2.39m)**
- **Maximum Travel Speed .77 MPH (1.24 km/hr.)**
- **Worldwide Access to Aftermarket Product Support**
- **Ground Clearance Minimum 9" (230mm)**
Clearance allows movement over rough terrain without damage



Quality Engineering By Design...Requires Industry Leading Brands

Simply stated...many manufacturers of moving undercarriage components, including link assemblies, rollers, idlers & sprockets, (which represents up to 75% of the cost of the completed lower arrangement) do not have the stringent processes in place that yield quality components. Varying hardness levels, material specifications & manufacturing processes will often produce an inferior component leading to unpredictable wear rates, service points & ultimately destruction. The result is increased & unscheduled downtime causing increased operating costs and lower profits. Caterpillar® moving undercarriage components all go through special heat treating processes which provide consistent surface hardness, superior hardened depth & core hardness levels. The resultant components, be it a link, roller, sprocket or idler, have a distinct metallurgical advantage which yields superior wear resistance, strength & durability for long term service life. Screen Machine Industries, Inc. is committed to utilizing name brands that deliver maximum performance at the lowest operating costs per hour.



SCREEN BOX

- **5'-0" x 16'-0"** (1.5 x 4.9m) **Double Deck Two Bearing Screen**
Capacity matched to upwards of 600 tons per hour, subject to material specifications
- **3/8"** (9.5mm) **Grade 80 US Steel Screen Box**
Heavy duty wear resistant plate for extra long life
- **Hydraulically Adjustable Screen Angle Includes 4 Operating Positions Ranging From 8 to 20 Degrees**
Match the screen angle to material for efficient screening of all types of products
- **Top Deck 5' x 16'** (1.5 x 4.9m) **Accepts Wire Cloth, Punch Plate or Finger Screens**
- **Bottom Deck 5' x 12'** (1.5 x 3.7m) **Accepts Wire Cloth, Harp Style or Finger Screens**



- **SMOOTH START™ Technology** (US Patent # 6,669,026)

At slow speeds, the screen shaft rotates perfectly round, creating zero elliptical throw (no shake at all) As the screen shaft RPM approaches operating speed, the counterweight extends outward creating the appropriate elliptical shake necessary to screen your material. This process also works in reverse during your machine shutdown. *Smooth Start™* technology eliminates the risk of machinery damage caused by slow speed violent shaking during your warm-up or cool-down periods. This fine example of American ingenuity is patented to deliver exclusive long term value.



RETRACTED
(SLOW)



EXTENDED
(FAST)



- **Heavy Duty Ladder and Catwalk Accessibility**

Quality engineering by design includes all areas of safety and maintenance

- **Screen Box Separates From Unders Conveyor To Create A Working Platform**

Our service-minded design creates easy accessibility for changing bottom screens



STRUCTURE

- **Massive Unibody Structure Features Unrivaled Deep Frame Design**
Massive unibody frame handles the high stresses of uneven loading during operation and rough terrain during movement.
- **USA Grade 80 Steel Construction**
High strength wear resistant steel ensures long life structural integrity to address the most demanding jobsite applications
- **Elevated Frame Design Equates To Rapid Deployment And Set Up**
11" ground clearance uniquely eliminates the need for any machine disassembly or site preparation prior to movement. **Enjoy the true wireless remote operation by never leaving the cab of your loader to reposition your machine.**





KEY FEATURES

POWER SYSTEM & CONTROLS

- **Cummins® Tier 3 Four Cylinder 110 HP Diesel Engine**
110 HP @ 2200 RPM turbocharged and charge air cooled
40% fewer parts than traditional diesel engines - greatly limiting the potential for areas of wear and oil leakage.
Supported by the largest parts and service network in the world
- **75 Gallon Fuel Tank (284 liters) With Lockable Fuel Cap**
Two full days of production as approximate runtime at 4.5 GPH is 16.7 hours
- **120 Gallon (454 liters) Hydraulic Tank is Baffled and Lockable**
- **Oilair® Hydraulic Oil Cooler**
From large hose diameters and fittings, to baffled tanks and coolers, our hydraulics run cool so your productivity can run hot!
- **Five (5) Emergency Stops** (includes one on the wireless remote handset)
- **Remtron® Wireless Remote Control Movement and Operation**
True portability is found in never having to leave the safety and comfort of the feed operators cab while in control of production
- **Locked Control Panels & Electronic Murphy® Shut Offs**
- **Large Engine Compartment For Ease of Maintenance** (large enough to stand upright inside)
- **Independent Hydraulics**
One pump, valve and motor for every single function on the machine



CONVEYORS

- **US Patent # 6,698,594**
Innovative design has earned the SPYDER 516T a patent separating it from all the rest
- **Open Flow Design Carries Oversized Product In A Straight Line**
Impact bed protected conveyor accepts your oversize rocks without concern
- **Side Stackers Feature Variable Height Adjustment**
- **All Discharge Conveyor Belts Feature Variable Speed Control**
Match belt speeds with your belt angle for optimal stockpiling capability
- **Cleated Midsize and Oversize Conveyor Belts**
Whether your windrowing stockpiles, feeding oversize into a crusher or loading out trucks - our discharge heights are impressive. The 516T helps make the most of available site space before you're compelled to move the plant.
- **Guide Rollers On All Conveyor Belts**
Guide rollers ensure centered belt tracking, eliminating spillage, damage and downtime
- **Transition Chutes Made Of 3/8" USA Grade 80 Steel**
All major transitions are fabricated with wear resistant steel to alleviate premature wearouts
- **Precision® Lagged Head and Wing Type Tail Pulleys**
- **Goodman® Rubber Disc Return Idlers** (great for sticky materials)

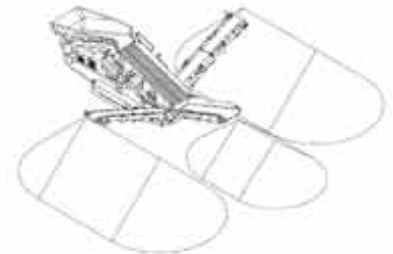

Fines Belt Discharge Height 12'- 6" (3.8m)
Midsize Belt Discharge Height 13' - 0" (3.8M)
Oversize Belt Discharge Height 9' - 6" (2.9m)

PRODUCT SUPPORT

- **Factory Headquarters Located In Columbus, Ohio**
- **Lifetime Toll Free Engineering Telephone Support** (USA only)
- **USA Sourced Name Brand Parts**
- **Rapid Response Parts Availability**
- **Extensive Distributor Network**
- **Detailed Operational, Service & Parts Manuals**

WHY THE SCREEN MACHINE ?

- **Screen Machine Industries, Inc. invests what is necessary to build your SPYDER 516T with name brand components, wear resistant steel, proper impact beds and features required for long term, maintenance free, reliable productivity. Which of these features can you afford to be without? We welcome the opportunity to be compared so that our true value can be identified.**



OPERATING DIMENSIONS

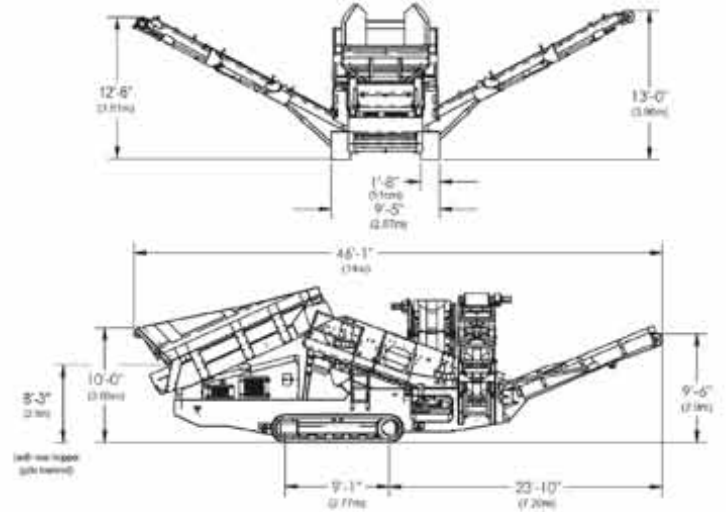
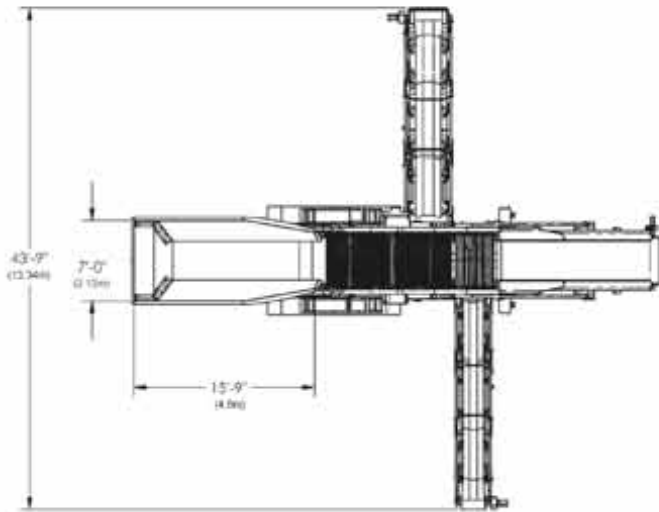

TRANSPORTATION DIMENSIONS

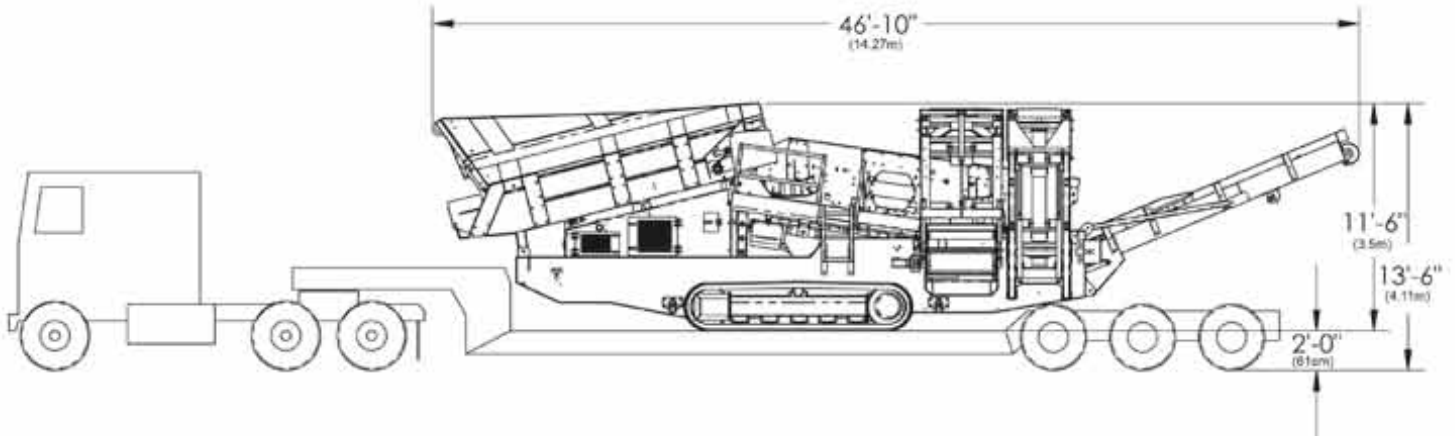

Length 46' - 10" (14.27m)
 Width 9' - 6" (2.9m)
 Height 11' - 6" (3.51m)
 Height w/optional grizzly 11' - 8" (3.56m)
 Weight 55,700 lbs. (25,265kg)
 Weight w/optional grizzly 59,000 lbs. (26,762kg)

SCREEN MACHINE INDUSTRIES, INC.

AN AMERICAN MANUFACTURER OF PORTABLE CRUSHING AND SCREENING EQUIPMENT

Screen Machine Industries, Inc. is an innovative American manufacturer of portable machinery dedicated to material crushing, screening, washing and stockpiling. Our product offering provides production solutions across a vast array of applications ranging from 15 – 600 tons/yards per hour (rock, sand & gravel, concrete & asphalt, topsoil & compost products, just to name a few). Our engineering design philosophy of incorporating only industry leading brand name components and feature rich competitive advantages has prominently influenced our 40+ years of success.



Screen Machine Industries, Inc.
Corporate Headquarters

The manufacturing process includes the utilization of high definition plasma tables, CNC fabrication equipment, robotic welders, advanced painting facilities and highly skilled mechanical technicians assembling these machines. Multiple levels of quality control and thorough run-time inspections are in place to ensure the quality and reliability that we demand and that you expect.



Screen Machine Industries, Inc. continues to make substantial investments in research and development. Our highly skilled engineers, combined with the latest computer technology, create the most innovative products in the screening industry. Numerous US Patents have been awarded as a result of our creative ambition in developing machinery superior to any in the world. We also strive to add the best design engineers to our organization. Several of our engineers are graduates of MIT and other prestigious universities throughout the United States. Our machines are designed to handle the most rugged demands our customers require.



Our diverse product line consists of heavy-duty track-mounted Jaw and Impact Crushers, Spyders, Scalper, Trommel and Conventional Screening and Shredding Plants. Portable Radial Stacking Conveyors complete the product line with sizes available to fit most every job.



SCALPER 107T



612T TROMMEL



SCALPER 77C



SCALPER 107D



4043T IMPACT CRUSHER

SCREEN MACHINE INDUSTRIES, INC

10685 Columbus Parkway
Pataskala, Ohio 43062 USA
1-740-927-3464 800-837-3344 (USA Only)
email@screenmachine.com
www.ScreenMachine.com

DISTRIBUTED BY: