

SCREEN MACHINE INDUSTRIES, INC.

AN AMERICAN MANUFACTURER OF PORTABLE CRUSHING AND SCREENING EQUIPMENT

JXT & JHT JAW CRUSHER



10685 COLUMBUS PARKWAY, ETNA, OHIO 43062 USA
1-740-927-3464 1-800-837-3344 WWW.SCREENMACHINE.COM

JXT & JHT OVERVIEW

Screen Machine Industries is a global leader in crushing and screening equipment with manufacturing headquarters located in Columbus, Ohio, USA.

Directionally reversible, 42" wide conveyor with impact bed, rebar guard and guide idlers creates maintenance free material flows

Caterpillar® C-9 Tier III ACERT engine coupled directly to the crusher through a *Transfluid®* fluid coupling eliminates costly mechanical clutch problems or expensive hydraulic issues

State of the art **Tramp Iron Relief** feature automatically senses and bypasses uncrushables continuously during operation (JXT Only)

USA Sourced GRADE 80 steel construction for strength and durability



Crossbelt magnet with stainless steel cladding and chutes to prevent magnetic material buildup

Multiple catwalks and lockable access doors create ease of maintenance

Remote Control Hydraulic Adjustment For Positioning Closed Side Setting of Jaw (JXT & JHT)

Track-mounted design with easy to use wireless remote control allows for quick and efficient setup and operation

Industry unique **Hydraulic Blockage Clearance** facilitates maximum productivity (JXT Only)

JXT & JHT JAW FEATURES

JAW CRUSHER

- Rigid one-piece fabricated base frame is reinforced for unmatched durability and strength
- Toeless pitman design prevents material build up at crusher discharge outlet
- 1 ¼" (32mm) throw on the eccentric shaft creates a constant downward force on material
 - Large throw leads to higher production rates
- Four manganese jaw dies are reversible and interchangeable
 - Compact size of dies allows for ease of handling
 - Identically sized die is used on all four die sections
- Rebar guard under crusher protects conveyor belt
- Protective grate above crusher keeps large material in crusher chamber
- Catwalks on both sides provide ease of maintenance



CRUSHING ACTION

- Steep toggle angle creates strong toe action
 - Creates crushing force over the full face of the chamber
 - Large throw on eccentric leads to higher production rates
- More toe action equates to more crushing throughput
 - Strong toe action decreases chance of plugging when processing sticky materials

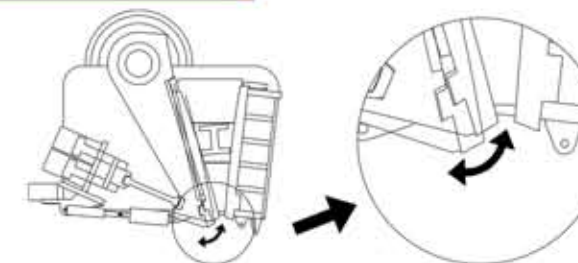

JAW ADJUSTMENT



- Hydraulics allow the jaw to be adjusted quickly and easily by the wireless remote control or the control panel
 - Can be operational within minutes
- Low pressure hydraulic system uses common components for ease of maintenance
- Hydraulic cylinder combined with mechanical spring creates constant tension on the toggle without wear on hydraulic components
 - No tension bolts to loosen or re-tension in order to adjust the jaw opening

JAW SIZE

- Actual jaw size [Depth (A)] measures 26" (66cm) from peak of jaw die to peak of jaw die on new and unworn dies
 - Measured without the jaw dies yields a 32" (81cm) dimension
- Actual jaw size [Width (B)] measures 44 ½" (1.13m) inside of unworn liner plate to inside of unworn liner plate
 - Measured without the liner plates yields a 46 ½" (1.18m) dimension
- The larger the die opening, the larger the possible raw material size
 - Inconsistent measuring of jaw opening, either without dies, with heavily worn dies or from valley to valley of dies, can lead to misleading size claims and lower production capabilities
 - Accurate jaw sizing and true crushing action determine true production rates and profitability

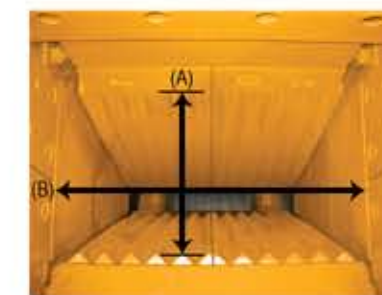

HYDRAULIC RELEASE SYSTEM (JXT ONLY)

BLOCKAGE CLEARANCE

- Screen Machine Industries' exclusively designed control system
- Jaw can be opened with the remote control to clear a blockage
Upon clearing jaw will return automatically to the previously set limit



TRAMP IRON RELIEF

- State of the art Tramp Iron Relief System protects the jaw when an uncrushable enters the jaw chamber
- Jaw automatically returns to previously set limit after the tramp iron has cleared
- True "adjust on the fly" capability via hydraulic adjustment during operation



Visit www.screenmachine.com to view video animation



Specifications Subject To Change Without Notice

JXT & JHT KEY FEATURES

ENGINE

- Caterpillar® C-9 Tier III ACERT 300 HP diesel engine
- Large lockable engine compartment
Walk-in area provides ease of maintenance on all service access points
- 175 gal (663L) fuel tank and 105 gal (398L) hydraulic tank with hydraulic cooler



FLUID COUPLING

- Transfluid® hydraulic fluid coupling
Provides smooth startup and shutdown operations of crusher without the risk of excessive wear or catastrophic failure
- Designed to permit instantaneous crusher stoppage due to steel or other large uncrushable material
Slips fluid on fluid, causing no wear, unlike mechanical clutches
Operator can uniquely disengage the crusher, move the machine and re-engage the crusher as quickly as you can read this

STRUCTURE



- Massive unibody structure features unrivaled deep frame design
Massive unibody frame handles the high stresses of uneven loading during operation and rough terrain during movement
- USA Grade 80 steel construction
Grade 80 steel's yield strength of 80,000 psi is more than double the yield strength of mild steel's 36,000 psi. While Grade 80 steel may look the same as other steel, Grade 80 steel prolongs the life of key machine components while helping keep the overall machine transport weight manageable
- Elevated frame design equates to rapid deployment and set up
High ground clearance uniquely eliminates the need for any machine disassembly or extensive site preparation prior to movement

UNDERCARRIAGE

- Heavy-duty design for optimum grade climbing ability
Low speed for maneuvering and high speed for long distance travel
- Track operation is controlled from a safe distance via remote control
- 24" (600 mm) wide pads create low ground pressure



REMOTE OPERATING SYSTEM & CONTROL PANEL



- Cattron® wireless remote control with 300 ft. (91M) range
Variable speed feeder with feeder shutoff
Crusher relief and jaw size settings
Full track motion and speed (high and low)
Engine shutoff control button
- Wireless remote means never leaving the safety of the loader cab to reposition the JXT/JHT and resume material processing
- Detailed control panel allows for ease of operation
- Four emergency stops mounted on machine for safety
- Optional tethered pendant controller

FEEDER



- 40"x13'-0" (1M x 4M) vibratory grizzly feeder
- 14'-0" (4.3M) long feed hopper opening
- Fixed hopper allows for quick setup and teardown
No folding hopper walls to manipulate
- Grade 80 steel hopper wall construction
- AR400 replaceable liner plates on feeder deck
- T1 tapered grizzly bars for pre-screening
- Variable speed feeder range from 600 to 900 rpm
- Sheave drive allows hydraulic motor to work in optimal speed range, resulting in long life of motor
Hydraulic motor is protected from falling debris and loaders
- Automatic feeder shutoff to prevent overload if jaw speed drops
Feeder automatically restarts at recovered jaw speed

CONVEYORS



- **Main Belt:**
42" (107cm) wide 440 PIW Global[®] belt
10'-9" (3.27M) main belt discharge height, reversible in direction
Precision head & tail pulleys with spherical roller bearings
Martin Engineering[®] belt scraper for optimum cleaning
Large Dodge[®] reducer with hydraulic drive motor
Impact bed below crusher discharge prevents belt wear
Rubber disc return rollers and guide idlers on all belts
- **Side Stacker:**
Fines side conveyor with 24" (600mm) belt and 7'-0" (2.13M) discharge height
Crusher bypass lever allows for optional fines removal to side stacker
- **Optional Dust Suppression System**



MAGNET

- Cross belt permanent magnet
Four adjustable corner ratchets allows for optimal positioning above material
- Reversible direction
- Heavy-duty belt with stainless steel cladding and flights for extended life
- Stainless steel chutes on both sides of conveyor
Prevents magnetic material buildup on chutes
- Stainless steel impact bed with UHMW liner mounted under magnet
Prevents magnetic material buildup on rollers while discharging metals



SERVICEABILITY

- Multiple non-slip platforms with ladders
- Key lock doors to service locations and tool storage compartment
- Service manuals in book form or electronic format
- Rapid response parts availability
- Free lifetime telephone and email technical support



OPERATING DIMENSIONS

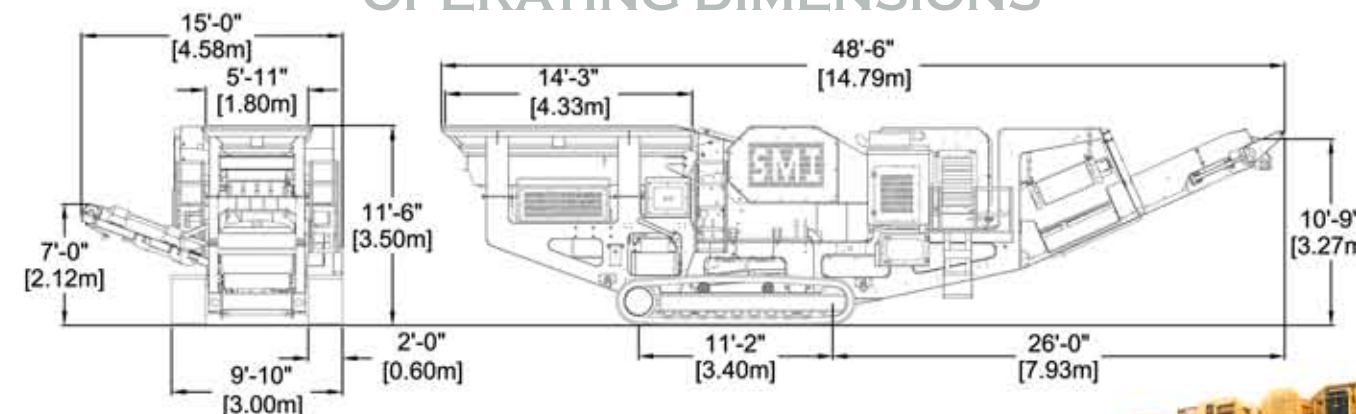

TRANSPORTATION DIMENSIONS

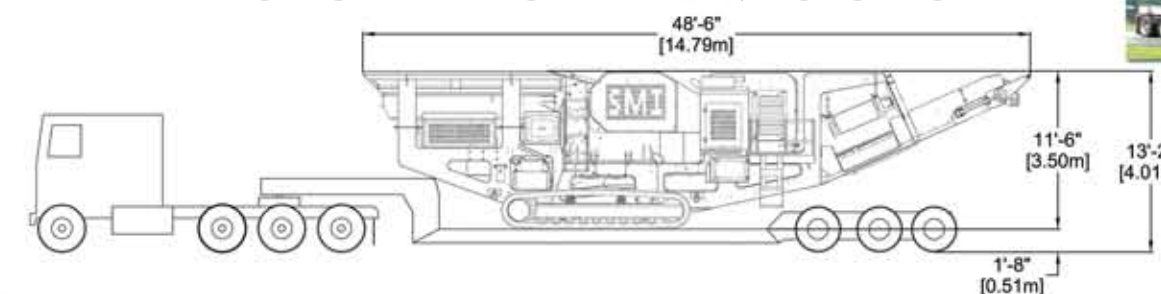

Length: 48'-6" [14.79M]
Width: 9'-10" [3.00M]
Height: 11'-6" [3.50M]
Weight: 98,000 lbs [44,452 kgs]

SPYDER 512T



For more information about the Spyder 512T visit www.screenmachine.com

Screen Machine Industries' Spyder 512T is a perfect match to the JXT/JHT Jaw Crusher. This wireless remote controlled 3-way split screening plant satisfies the need for a heavy-duty machine to process large volumes in the most demanding applications. This unit can operate alone, or in tandem with the JXT/JHT Jaw Crusher (as shown below).

Features include:

- Patented overall machine design allows loaders to uniquely feed from 3 sides of the hopper while maintaining a safe distance from conveyors and stockpiles
- Massive structural components manufactured from Grade 80 USA Steel for superior durability
- Leading American brand name components to ensure peace of mind investment
- Impact beds and apron feeders support severe duty applications
- Straight pass through design engineered to process large oversize materials
- 5'x12' (1.5M x 3.7M) double deck shaker screen uses patented **Smoothstart**[™] technology



PATENT
6,669,026



PATENT
6,698,594

Spyder 512T is covered by
US patents 6,669,026 and 6,698,594



SCREEN MACHINE INDUSTRIES, INC.

AN AMERICAN MANUFACTURER OF PORTABLE CRUSHING AND SCREENING EQUIPMENT

Screen Machine Industries, Inc. is an innovative American manufacturer of portable machinery dedicated to material crushing, screening and stockpiling. Our product offering provides solutions ranging from 15-600 tons/yards per hour across a vast array of applications (such as sand & gravel, concrete & asphalt, topsoil & compost products). Our successful engineering philosophy is to incorporate reliable brand name components and industry leading features with the highest quality manufacturing techniques. This philosophy has prominently driven our success since 1966.



Screen Machine Industries, Inc.
Corporate Headquarters

The manufacturing process includes the utilization of CNC fabrication equipment, robotic welders, advanced painting facilities and highly skilled mechanical technicians assembling these machines. Multiple levels of quality control and thorough run-time inspections are in place to ensure the quality and reliability that we demand and that you expect.

Screen Machine Industries, Inc. continues to make substantial investments in research and development. Our highly skilled engineers combined with the latest computer technology, create the most innovative products in the crushing and screening industries. Numerous U.S. Patents have been awarded as a result of our creative ambition in developing machinery that we feel is superior to any in the industry. We also strive to add the best design engineers available to our organization. Our engineers are graduates of MIT and other prestigious universities throughout the United States.

Our diverse product line consists of heavy-duty, track-mounted Jaw and Impact Crushers, Spyders, Scalpers, Trommels and Conventional Screening and Shredding Plants. Our portable stacking conveyors complete the product lineup with sizes available to fit most every job.



SCALPER 107T



612T TROMMEL



SCALPER 107D



4043T IMPACT CRUSHER



JXT/JHT JAW CRUSHER



SCREEN MACHINE INDUSTRIES, INC

10685 Columbus Parkway
Etna, Ohio 43062 USA

1-740-927-3464 800-837-3344 (USA Only)

Email@screenmachine.com

www.screenmachine.com



DISTRIBUTED BY: