

SCREEN MACHINE INDUSTRIES, INC.

AN AMERICAN MANUFACTURER OF PORTABLE CRUSHING AND SCREENING EQUIPMENT

4043T IMPACT CRUSHER

WEIGHT: 79,500 LBS
(36,061 KGS)



10685 COLUMBUS PARKWAY, ETNA, OHIO 43062 USA

1-740-927-3464 800-837-3344 (USA ONLY) WWW.SCREENMACHINE.COM

OVERVIEW

Screen Machine Industries is a global leader in crushing and screening equipment with manufacturing headquarters located in Columbus, Ohio, USA.

KEY FEATURES

CRUSHER

- 40" (1.02m) x 43" (1.09m) horizontal impact crusher
 Years of proven engineering and design reliability
- Large 43" wide (1.09m) x 32" (.81m) high feed inlet opening
- Variable speed control from 600-700 rpm
- Two fully adjustable aprons
 For multi-stage crushing
- Remote *Crusher Relief System* (U.S. Patent # 7,229,041)
- Low chrome ceramic reversible blow bars (standard)
 Optional high chrome ceramic or low chrome steel blow bars
- 4 bar rotor design
 2 active low chrome ceramic bars & 2 inactive low chrome steel "dummy bars"

Visit www.screenmachine.com to view working jobsite videos of the 4043T Impact Crusher



CRUSHER RELIEF SYSTEM

- Raise and lower of crusher lid and attached aprons
- Crusher lid operated by remote control
- Hydraulically raise crusher lid up to 6" during full operation
 Effectively clears marginally oversized and bridged materials (raise opening from 32" to 38")
 Eliminates the need to reduce feed volume for fear of material bridging
- U.S. Patent # 7,229,041



As the lid lifts up, the increase in opening height will dislodge most bridged materials that otherwise would completely shut-down production for a significant period of time.

The entire crusher lid with attached aprons can raise during operation.

Two hydraulic cylinders raise the crusher lid relative to the rotor.

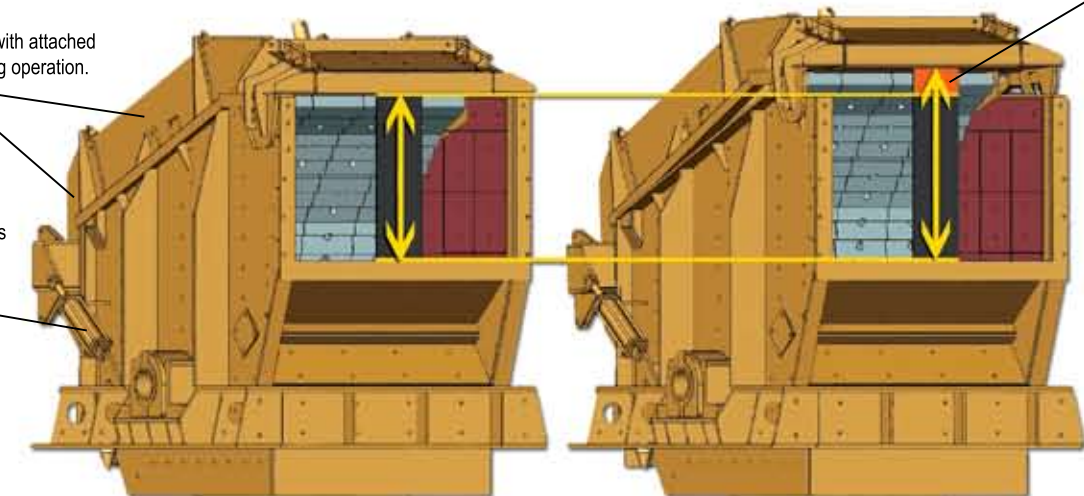

Operating Position

Blockage Clearance

Multiple safety features including sensors, mechanical stops and material guards guarantee safe operation.

Directionally reversible, 42" wide conveyor with impact bed and guide idlers creates maintenance free material flows

Caterpillar® C-9 300 HP Tier III ACERT engine coupled directly to the crusher through a *Transfluid®* fluid coupling eliminates costly mechanical clutch problems or expensive hydraulic issues

USA Sourced GRADE 80 steel construction for strength and durability



Crossbelt magnet with stainless steel cladding and chutes to prevent magnetic material buildup

Multiple catwalks and lockable access doors create ease of maintenance

Heavy-duty tracked undercarriage with easy to use wireless remote control allowing for quick and efficient setup and operation



Industry unique and patented **Remote Controlled Crusher Relief System** clears blockages and maximizes productivity

ENGINE

- Power supplied by a Caterpillar® C9 300 HP Tier III ACERT diesel engine
- Electronic control of engine speed ranges from 1800 to 2200 rpm
- 6 cylinder water-cooled with 4 Murphy® shut-downs
- Large, lockable engine compartment with easy walk-in maintenance access
 - Provides ease of maintenance on all service access points
- 175 gallon (663 liter) fuel tank and 105 gallon (398 liter) hydraulic tank
 - Hydraulic cooler maintains a cool running hydraulic system



FLUID COUPLING

- Transfluid® fluid coupling
 - Provides smooth startup and shutdown operations of crusher without the risk of excessive wear or catastrophic failure
- Designed to permit instantaneous crusher stoppage due to steel or other large uncrushable material
 - Slips fluid on fluid, causing no wear, unlike mechanical clutches.
 - Operator can uniquely disengage the crusher, move the machine and re-engage the crusher as quickly as you can read this

UNDERCARRIAGE



- The 4043T impact crusher utilizes a heavy-duty tracked undercarriage
 - Ensuring long term reliability, world-wide parts availability and product support
- Track operation is controlled from a safe distance
 - Wireless remote control handset used for movement and operation

STRUCTURE

- Massive unibody structure features unrivaled deep frame design
 - Unibody frame handles the high stresses of uneven loading during operation and rough terrain during movement
- USA sourced Grade 80 steel construction
 - High strength wear resistant steel ensures long life structural integrity to address the most demanding jobsite applications
- Elevated frame design equates to rapid deployment and set up
 - 11" ground clearance uniquely eliminates the need for any machine disassembly or site preparation prior to movement



REMOTE OPERATING SYSTEM & CONTROL PANEL

- Remtron® wireless remote control with 300 ft. (91m) range
 - Variable speed feeder with feeder shutoff
 - Crusher relief system
 - Full track motion and speed (high and low)
 - Movement left, right, forward and backward
 - Engine shutoff control button
- Wireless remote means never leaving the safety of the loader cab to reposition the 4043T and resume material processing
- Detailed control panel allows for ease of operation
- Four emergency stops mounted on machine for safety
- Optional Tethered Pendant Movement



FEEDER



- 40"x13'-0" (1m x 4m) vibratory grizzly feeder
- 14'-0" (4.3m) long feed hopper opening
- Fixed hopper allows for quick setup and teardown
 - No folding hopper walls to manipulate
- Grade 80 steel hopper wall construction
- AR400 replaceable liner plates on feeder deck
- T1 tapered grizzly bars for pre-screening
- Variable speed feeder range from 600 to 900 rpm
- Sheave drive allows hydraulic motor to work in optimal speed range, resulting in long life of motor
 - Hydraulic motor is protected from falling debris and loaders

MAGNET

- Cross-belt permanent magnet
 - Four corner ratchet adjustment for raise and lower
- Reversible direction
- Heavy duty belt with armor plating and flights for extended belt life
- Stainless steel chutes on both sides of the conveyor
 - Prevents magnetic material build-up
- Impact bed under magnet for optimal controlled performance
- Variable speed magnet belt



CONVEYORS



- Main belt:
 - 42" (1.07m) wide 440 PIW Global® belt
 - 10'-9" (3.28m) main belt discharge height, reversible in direction
 - Precision® head & tail pulleys with spherical roller bearings
 - Martin Engineering® belt scraper for optimum cleaning
 - Large Dodge® reducer with hydraulic drive motor
 - Impact bed below crusher discharge prevents belt wear
 - Rubber disc return rollers and guide idlers on all belts
- Side stacker:
 - Fines side conveyor with 24" (600mm) 220 PIW belt
 - 7'-0" (2.11m) discharge height
 - Crusher bypass lever allows for optional fines removal
- Optional dust suppression system



SERVICEABILITY

- Split crusher housing for complete maintenance access
- Multiple non-slip platforms with ladders
- Key lock doors to service locations and tool storage compartment
- Service manuals in book form or electronic format
- Rapid response parts availability
- Free lifetime telephone and email technical support

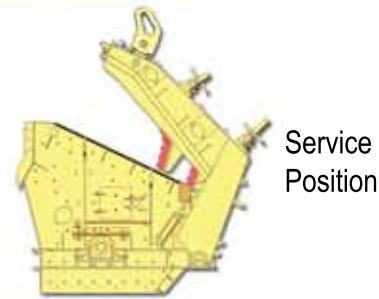

SPYDER 512T



Screen Machine Industries' Spyder 512T is a perfect match to the 4043T Impact Crusher. This wireless remote controlled 3-way split screening plant satisfies the need for a heavy-duty machine to process large volumes in the most demanding applications. This unit can operate alone, or in tandem with the 4043T Impact Crusher (as shown below).

Features include:

- Patented overall machine design allows loaders to uniquely feed from 3 sides of the feeder while maintaining a safe distance from conveyors and stockpiles
- Massive structural components manufactured from Grade 80 USA Steel for superior durability
- Leading American brand name components to ensure peace of mind investment
- Impacts beds and apron feeders support severe duty applications
- Straight pass through design engineered to process large oversize materials
- 5'x12' (1.5m x 3.7m) double deck shaker screen uses patented **Smoothstart®** technology

For more information about the Spyder 512T visit www.screenmachine.com



Spyder 512T is covered by US patents 6,669,026 and 6,698,594



OPERATING DIMENSIONS

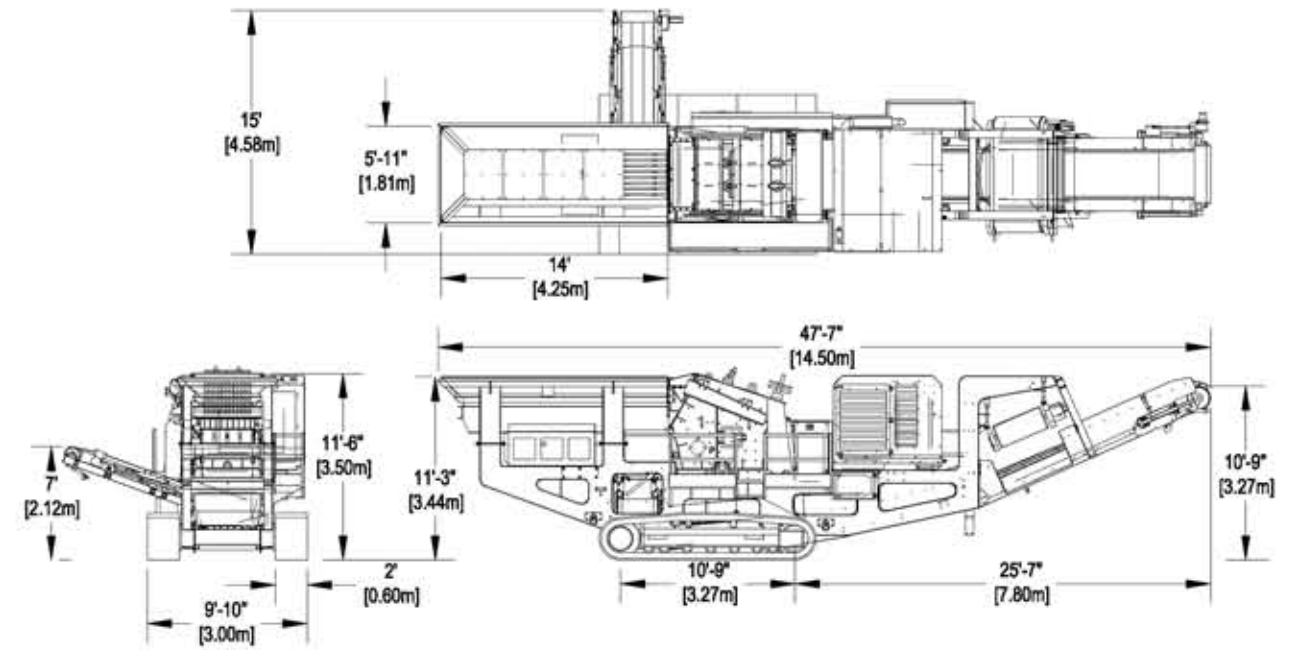

TRANSPORTATION DIMENSIONS

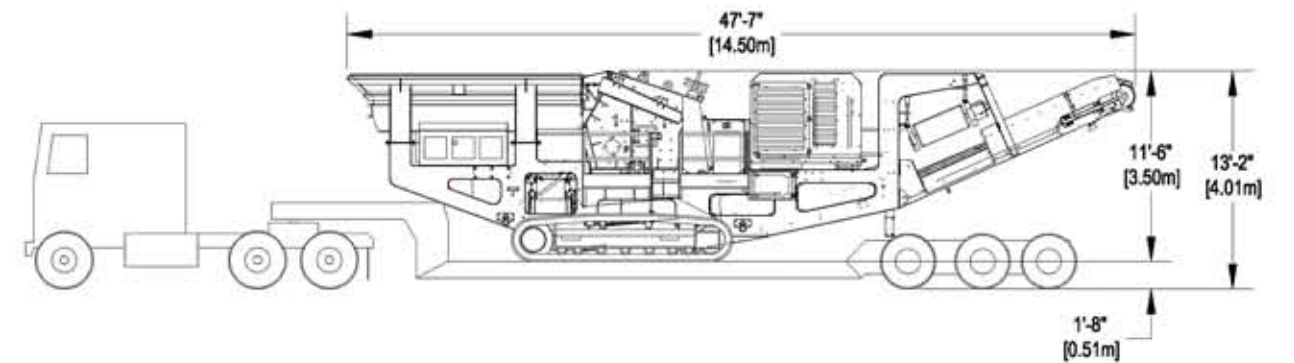

Length: 47'-7" [14.15m]
 Width: 9'-10" [3.00m]
 Height: 11'-6" [3.50m]
 Weight: 79,500 lbs
 [36,061 kgs]

DESIGNED FOR EASE OF TRANSPORT TO JOB SITE

SCREEN MACHINE INDUSTRIES, INC.

AN AMERICAN MANUFACTURER OF PORTABLE CRUSHING AND SCREENING EQUIPMENT

Screen Machine Industries, Inc. is an innovative American manufacturer of portable machinery dedicated to material crushing, screening, washing and stockpiling. Our product offering provides production solutions across a vast array of applications ranging from 15 – 600 tons/yards per hour (rock, sand & gravel, concrete & asphalt, topsoil & compost products, just to name a few). Our engineering design philosophy of incorporating only industry leading brand name components and feature rich competitive advantages has prominently influenced our 40+ years of success.



Screen Machine Industries, Inc.
Corporate Headquarters

The manufacturing process includes the utilization of high definition plasma tables, CNC fabrication equipment, robotic welders, advanced painting facilities and highly skilled mechanical technicians assembling these machines. Multiple levels of quality control and thorough run-time inspections are in place to ensure the quality and reliability that we demand and that you expect.



Screen Machine Industries, Inc. continues to make substantial investments in research and development. Our highly skilled engineers, combined with the latest computer technology, create the most innovative products in the screening industry. Numerous US Patents have been awarded as a result of our creative ambition in developing machinery superior to any in the world. We also strive to add the best design engineers to our organization. Several of our engineers are graduates of MIT and other prestigious universities throughout the United States. Our machines are designed to handle the most rugged demands our customers require.



Our diverse product line consists of heavy-duty track-mounted Jaw and Impact Crushers, Spyders, Scalper, Trommel and Conventional Screening and Shredding Plants. Portable Radial Stacking Conveyors complete the product line with sizes available to fit most every job.



SCALPER 107T



612T TROMMEL



SCALPER 77C



SCALPER 107D



JXT/JHT JAW CRUSHER

SCREEN MACHINE INDUSTRIES, INC

**10685 Columbus Parkway
Etna, Ohio 43062 USA**

1-740-927-3464 800-837-3344 (USA Only)

Email@screenmachine.com

www.screenmachine.com



DISTRIBUTED BY: